



C MARSHALL FABRICATION MACHINERY, INC.
12836 W Calle De Sol, Peoria, AZ 85383 U.S.A.
(928) 252-6901 (866) 399-2323 FAX (928) 252-6903
E-MAIL: cary@cmarshallfab.com WEB-SITE: www.cmarshallfab.com

Double Pinch Hydraulic 4 Roll Plate Bending Machine Model **M3015C**



This is the ultimate evolution in the plate bending field with two dragging rolls with hydraulic pinching allowing a steady and precise material dragging. This plate bending machine is the easiest, most versatile, quickest and precise the market can offer.

All parts are selected among the best brands in the world to allow precision, long life and versatility. **CSA approved for the Canadian market.**

MAXIMUM LINE VOLTAGE 220/440, 3ph/60Hz

DETAILS

Technical data

Installed power	10 HP
Top roll diameter	11.4" (290 mm)
Lower roll diameter	10.6" (270 mm)
Side rolls diameter	8.3" (210 mm)

Capacity

Working length	126" (3100 mm)
Max. rolling thickness	19/32" (15 mm)
Max. pre-bend thickness	1/2" (13 mm)

The max performances are referred to shells of diameter equal or larger than **3 times** the top roll diameter and with material with a yield point 38,500 PSI

Standard equipment:

- Movable console
- Hydraulic system for opening the machine and removing the tube.
- Safety system to conform to EC Rules.

Parts used

Planetary Gear boxes	BREVINI, DINAMIC OIL (Italy)
Hydraulic Motors	SAI, INTERMOT (Italy)
Hydraulic Pumps	CASAPPA (Italy)
Hydraulic Valves	ARON, DUPLOMATIC (Italy)
Electric Parts	TELEMECANIQUE (France)
Bearing	SKF, FAG, RKB, HRB (Germany, Italy)
Forged Rolls	LUCCHINI, FMA, NUOVA OFAR, VIENNA (Italy)

Structural characteristics:

- Electro welded monolithic structure normalized and machined on the new generation CNC boring machines
- Exclusive integrated hydraulic system developed for high performance
- Parallelism control by means of massive torsion bars to guarantee high precision also where the newest hydraulic systems may fail.
- Permanent lubrication system
- Planetary movement of the rolls to avoid any kind of friction and to guarantee high precision for the machine life.

Size

Width	55" (1460 mm)
Total length	184" (4475 mm)
Height	59" (1520 mm)
Working height	38.7" (985 mm)
Weight	17,600 Lbs. (8 m tons)

PERFORMANCES

Performances are referred to working of materials with a yield point equal or lower of 38,500.

Increasing the material yield point, machine bending and pre-bending capacity will decrease, as you can see in the K factor chart (see chart).

Yield point	Tensile strength	Factor "K"	Example:
KSI	KSI		Machine with a pre-bend capacity of 1/2". Material yield point 41,000 Change the yield point to 70,000 the pre bend capacity reduces by 'K' factor of 0.70 pre bend capacity reduces to 5/16" [If in doubt ask]
50,000	75-95,000	0.84	
70,000	95-115,000	0.70	
100,000	115-140,000	0.60	
130,000	175,000	0.50	

CAPACITY CHART FOR M3015C

Width	Diameter	Bending Thickness	Prebend Thickness	Bending Thickness	Prebend Thickness	Bending Thickness	Prebend Thickness
FEET	INCHES	Material based on yield point 38,000 KSI		Material based on yield point 45,000 KSI		Material based on yield point 52,000 KSI	
10.171	12.559	0.354	0.307	0.319	0.276	0.298	0.258
10.171	17.126	0.472	0.409	0.425	0.369	0.397	0.344
10.171	34.252	0.591	0.512	0.531	0.461	0.496	0.430
10.171	57.087	0.620	0.537	0.558	0.484	0.521	0.451
10.171	114.173	0.650	0.563	0.585	0.507	0.546	0.473
8.476	12.559	0.388	0.336	0.349	0.303	0.326	0.283
8.476	17.126	0.518	0.449	0.466	0.404	0.435	0.377
8.476	34.252	0.647	0.561	0.582	0.505	0.543	0.471
8.476	57.087	0.679	0.589	0.611	0.530	0.571	0.495
8.476	114.173	0.712	0.617	0.640	0.555	0.598	0.518
6.780	12.559	0.434	0.376	0.391	0.338	0.365	0.316
6.780	17.126	0.579	0.501	0.521	0.451	0.486	0.421
6.780	34.252	0.723	0.627	0.651	0.564	0.608	0.527
6.780	57.087	0.759	0.658	0.683	0.592	0.638	0.553
6.780	114.173	0.796	0.690	0.716	0.621	0.668	0.579
5.085	12.559	0.501	0.434	0.451	0.391	0.421	0.365
5.085	17.126	0.668	0.579	0.601	0.521	0.561	0.486
5.085	34.252	0.835	0.724	0.752	0.651	0.702	0.608
5.085	57.087	0.877	0.760	0.789	0.684	0.737	0.638
5.085	114.173	0.919	0.796	0.827	0.717	0.772	0.669
3.390	12.559	0.614	0.532	0.552	0.479	0.516	0.447
3.390	17.126	0.818	0.709	0.736	0.638	0.687	0.596
3.390	34.252	1.023	0.886	0.921	0.798	0.859	0.745
3.390	57.087	1.074	0.931	0.967	0.838	0.902	0.782
3.390	114.173	1.125	0.975	1.013	0.878	0.945	0.819

MINIMUM PERFORMABLE DIAMETER

The minimum possible diameter to be bent depends on several factors such as:

- Top roll diameter
- Plate thickness
- Material

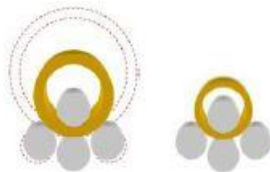

The machine top roll diameter influences the performance of the minimum diameter by the simple fact that you can't get a smaller diameter than the top roll.

As for the plate thickness, let's say we you using a machine with maximum capacity 4" X 10' length. We wish to bend a plate working at the maximum capacity. In this case the minimum possible diameter we'll get will be three times the top roll. Let's say we now wish to use the same machine at 60% of its maximum capacity. In this case we wish to bend a 10' plate with a 2-3/8" thickness; at this point the minimum diameter we get will be 1.1 times the top roll.

D min (full capacity) = 3 times the top roll diameter

D min (60% of capacity) = 1,1 times the top roll diameter

MG plate bending machines are designed and built on a basis of 38,500 PSI yield point material.

TECHNICAL AND STRUCTURAL FEATURES

- A) **Automatic simultaneous balancing:** bending roll parallelism controlled by massive TORSION BARS working in symbiosis with sophisticated valves controlling the oil flow. This system allows the complete and steady parallelism without resetting.

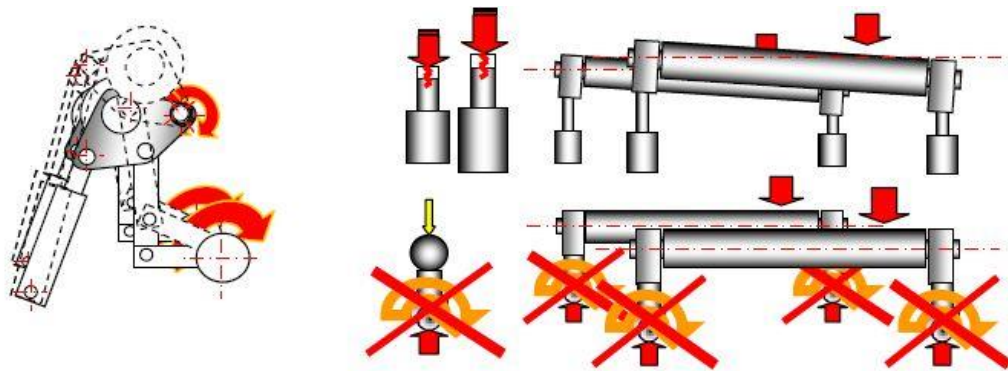

- B) **Planetary movements:** bending rolls planetary movement that reduces frictions to minimum, frictions very common on traditional movement machines, such as diagonal or horizontal sliding guides.

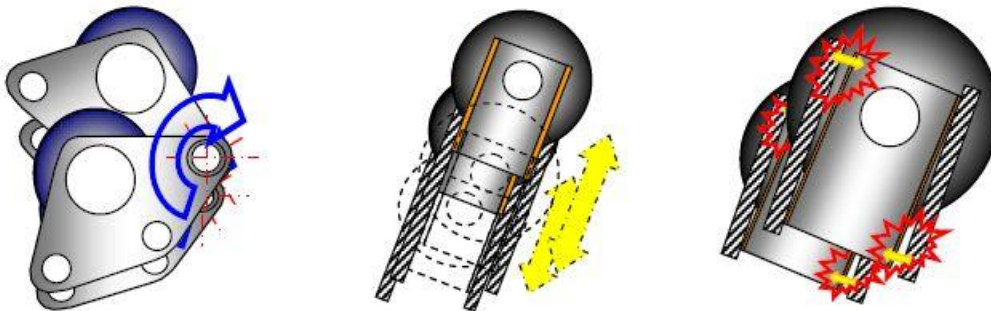

- C) **Permanent lubrication:** All machine components are pre-lubricated and sealed following a unique system allowing lubrication for the Life of machine.

D) **Direct drive:** Replacing of all low efficiency components (gears, bushings, mechanical gear boxes, transmission belts, sliding guides...) with the most efficient epicyclical gear boxes DIRECTLY COUPLED on the rolls, bearings and hydraulic motors, this way all machine strength is focused on the material to bend (positive strength) with consequent Energy saving. This system conforms to the “International High efficiency and Anti-Pollution” standards.

MOTORIZATION

An MG 4 roll plate bending machine motorization is made of two hydraulic motors directly coupled to the rolls by particular motion transmission gears and gear boxes that give the maximum performances with the minimum possible strength. The motion is given to the motors through a hydraulic pump, which is set in motion by an electric motor, it is successively given to the reducers and then to the rolls.

Furthermore, motorization is very important during the pre-bending phase, it allows you to position the plate at the center of the rolls with the maximum precision, without the material slipping. This is due to the fact that we are using a 4 roll machine, and can pinch the plate with the central rolls, thus, we get a pre-bending that will not be over 1.5 or twice the plate thickness itself.

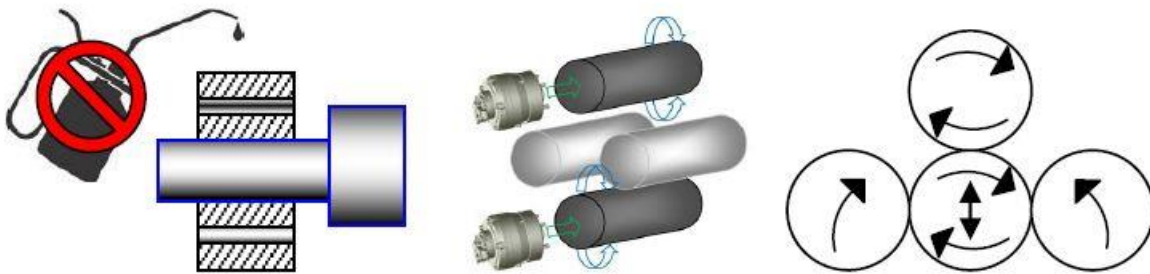

ROLLS CAMBERING

A good part of MG technology is the application variable cambering on the rolls on the basis of material thickness. Each MG machine is different from the others even among same models because the rolls do not have the same cambering. Furthermore, during the bending work a particular phenomenon takes place, a phenomenon that is not always visible: the rolls are subject to deflection, but, thanks to the cambering, they do not reach the breaking point, and allow a very good result in their bending performance.

PERMANENT LUBRICATION SYSTEM

Thanks to the using of high quality and high resistance materials, MG can grant a system of permanent lubrication. By using auto-lubricated bearings it will be enough only to grease the parts during the assembling. MG plate bending machines maintenance will not be necessary, only a periodical refilling of the oil will be necessary and of course cleaning the mill scale off machine occasionally.

FEATURES

- Electro-welded steel frames worked on CNC working stations.
- Rolls movement at variable speed from 0 to 100% (this does not include machines with electro-hydraulic controls and Lynx controlled).
- High performance Hydraulic motors, with energy saving, no secondary transmissions such as chains, gears, belts.
- Immediate stopping of all moments by over center valves.
- Variable speed shaping side rolls (this does not include machines with electro-hydraulic controls and Lynx controlled).
- Bending rolls by massive torsion bars.
- Central roll pressure setting by hydraulic valve; this grants the right pinching for every material thickness.
- Hydraulic opening system for pipes ejection.
- Top roll automatic balancing (for machine opening).
- Rolls mounted on high load double row bearings.
- Pinching rolls double cambering so to adapt to the natural deflection of rolls themselves during the working process, this will avoid all defects in a broader range of rolling.
- Machine wholly hydraulic.
- Pre-bending, bending and pipe closing in one pass (within suggested parameters)
- One operator only for all bending operations.

STANDARD COMPONENTS

- Integral hydraulic system, with all hydraulic protections at EC norms.
- Electrical systems complete with all “overload” protections at EC norms.
- Mobile control console for a secure and correct position of the operator.
- Hydraulic machine opening for the pipe removal.
- Multiple stop system that grants the best security.
- Side rolls that can be used for material squaring.

ADVANTAGES OF THE FOUR ROLLS PLATE BENDING MACHINE

The 4 roll plate bending machine is the easiest to use, thanks to a frame designed to satisfy every need. Advantages are many:

- Pre-bending is reduced because the material gets pinched between the two central rolls.
- Working can be made in one only pass, following the steps here below:

1. Squaring
2. Pre-bending
3. Bending
4. Closing pre-bending

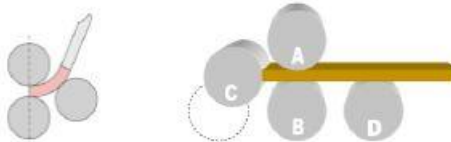

- The plate is fed into the machine horizontally thanks to the support of the lower roll (B) with the side roll (D).
- The plate is automatically squared thanks to the position that the side roll (C) takes.

- The space to the limit of the machine reduces to one side only, thanks to the possibility of squaring and bending in one only step.

We recommend a 4 roll plate bending machine:

- For a high and massive production
- For the possibility to control by CNC
- For the possibility to make conical bendings
- Because it's easy to use

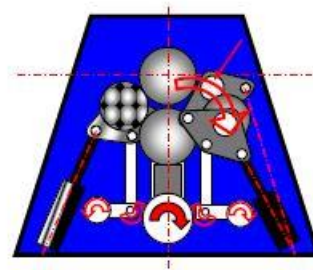

TOP ROLL CONTRAST TO EJECT PIPES

When the machine uses conical bending device, it does not allow the finished shell to be taken off. MG uses a unique system called contrast to eject the pipe. This particular system utilizes a piston mounted on the back side of the roll. This piston monitors the yoke position; when it's completely down, the piston moves and lifts the top roll to let the operator eject the pipe.

The monitoring is made by a valve, called a sequence valve that "senses" the pressure increasing in the hydraulic circuit when the yoke opens, transferring it to the contrast piston that, consequently, lifts the roll.

On CNC controlled machines, a pressure gauge is mounted on the sequence valve having the task of monitoring the pressure when the yoke closes. Reaching the pressure set by CNC, the pressure gauge will block the oil flow, stopping the pressure in the system.

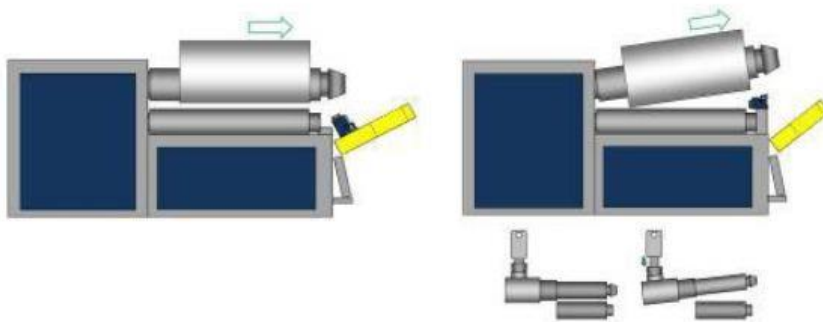

IMPORTANT CONSIDERATION

FLAT PART

If the choice of the machine has been made properly, the minimum flat part you get will be 1.5 or 2 times the plate thickness. Even in this case, the plate thickness and its yield point, relating to the machine capability makes a difference.

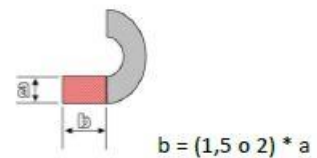

CONICAL BENDING

Conical bending with conicity over 4 degrees reduces machine performances. This is due to the unbalanced load on the top roll and its bearings. The more the cone tilts the more the machine performance will decrease, for a maximum of a 50% in length and in bending thickness.



ACCESSORIES

CENTRAL SUPPORT

MG Vertical Support has been developed to support the plate in every phases of the bending process. This helps us to keep the material stable without changing of the radiuses due to the weight of the plate.

The Central Beam is fully hydraulic and it is composed of a piston and two chains that control movements (UP and DOWN).

SIDE SUPPORT

MG Side Support has the function to support the plate during the bending process, in fact, during the rolling; it is possible to have problems due to the thickness and the weight of the plate. If the plate is very thin and we are going to roll a very wide diameter, the material is too weak to support itself, it will try to deform and thus change its radius. Using an MG Side Support, this will solve this problem.



FLAT PRODUCED WITH PRE-BEND

There is a theoretical possibility of achieving a flat each side of the longitudinal seam of the plate approximately 1½ to 2 times the material thickness. There are many variables that influence the ability to actually achieve this theoretical flat, the experience of the machine operator being a factor.

CONE ROLLING

When cone rolling, the machines capacity is reduced to ½ that of the pre bend capacity, i.e. ½ the thickness & ½ the length. When you pre bend a plate with the side rolls set parallel to the top roll, the bearing loading is equal at the end of each side roll; this loading changes when you tilt the side rolls to produce the cone, the side bearings at the drop end take approximately 80% - 100% of the loading.

GAUGING

During and after the rolling you will have the need to measure the radii; how will you do this? The normal method is radii templates. Do you already have these? This method is ok for small diameters. The measuring of large radii with large templates can be difficult; we recommend the purchase of our 'arch-meter' for larger radii measurements. The newly redesigned Arc Meter (Radius Gauge) includes the following benefits:



- High accuracy precision transducer
- Wireless data transmission
- Low power components for extended battery life
- Motion sensor ON/OFF function and display rotation
- Interchangeable arms for small or large radii
- Inch and mm units

COMMAND CONTROLS

a) CNC TOUCH COMMAND EVO

[Click the picture below for more information and video on the EVO control](#)

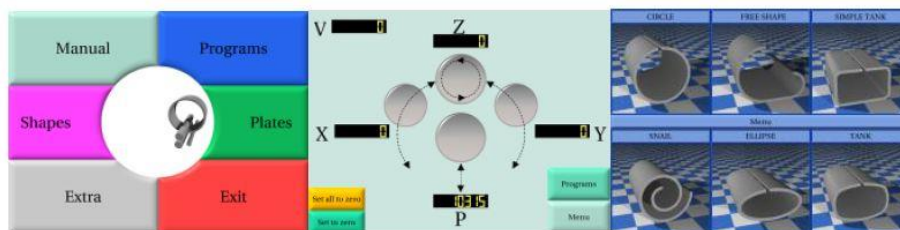

To handle a complete automatic cycle, we propose a Computerized Numeric Control called Touch Command that has been completely developed by MG Engineers. Software dedicated to our machines, instead of having the application applied to the control, as very often happens.

b) MG NUMERICAL NEXUS TOUCH SCREEN CONTROL

The new MG Numerical Control with all features of MG NC Lynx with following added and improved functions:

The possibility to control:

- Three bending axis (X Y Z)
- Two Side Supports
- Central support
- Pinching controller through pressure
- Power Ejector on/off
- Interface with PLC control power conveyor
- Archive 300 programs with 99 steps each
- Graphic interface Man / Machine through a tough screen panel.

DIAGNOSTIC SCREENS TO CONTROL THE CORRECT FUNCTIONALITY OF THE MACHINE AND ALL COMPONENTS (encoders, end stroke input and output relè).

[Click image below for video on the Nexus control](#)



**Closed shapes ejectors conveyors combined can complete the working cycle.
All accessories are CNC controlled.**

